

Upgrade to Next Generation

Upgrade your legacy 11SGE shut off valve to the Next Generation, and extend the life of your valve by introducing our recommended maintenance schedule.

Benefits of Upgrading

- Higher durability and vibration resistance
- Reduces the required activation pressure to improve reliability
- High quality o-ring seals for better serviceability
- Eliminates charge air leakage
- Larger manual action handle allows user to actuate valve with twist action
- Optimizes components for serviceability

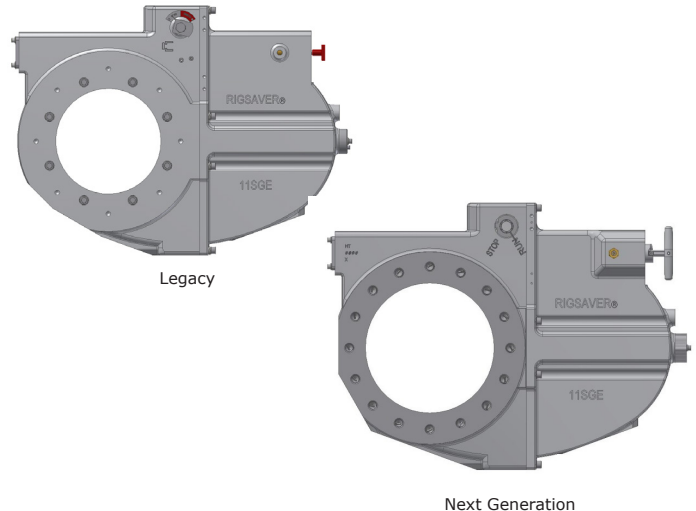

Applications

Diesel engines primarily for offshore power generation.

Engine Manufacturers

- CAT
- Wartsila
- EMD
- HHI
- Bergen
- MAN

*Note: These are registered trademarks of each referenced company.

Affected Products/Components

Legacy 11SGE (11 inch) shutoff valve manufactured before January 1, 2014.

- After extended periods of vibration, valve requires higher air pressure to activate or may have a tendency to false trip.
- Maintenance schedule of the shut off valve not previously provided

The shut off valve can be operated manually or pneumatically in the case of an emergency. It completely blocks the engine intake system, cutting off both the external fuel source and the air required to keep the engine running.

The level of vibration applied to the Rigsaver 11SGE shutoff valve varies by application and location on the engine.

Based on these factors, the reliability and performance of the valve may diminish over time. Rigsaver recommends the user verify performance with regular cycle testing and adhere to the maintenance schedule contained in this document. **Unless advised otherwise by the engine manufacturer, Rigsaver recommends that the testing procedure is conducted at engine start-up and weekly when in continuous service.**

Contact us to order now at
(1) 780-465-4429
sales@rigsaver.com

Maintenance Schedule

Once you have installed and tested the cover kit upgrade, we recommend you introduce the following maintenance schedule activities for this component.

Engine Hours on Valve Body	6,000	12,000	18,000	24,000
Spindle System Kit	●		●	
Gate Support Kit	●		●	
Cover Kit*		●		
Replace Valve				●

*Note: Includes Gate Support and Spindle System Kits

Kit Part Numbers

Contact Customer Service at (1) 780-465-4429 for the specific Kit Part Number for your valve.

NOTICE: RIGSAVER Scheduled Function Testing

- Use Emergency Stop button to actuate valve pneumatically
- DO NOT use manual override handle for function testing
- If valve fails to actuate, contact an AMOT representative

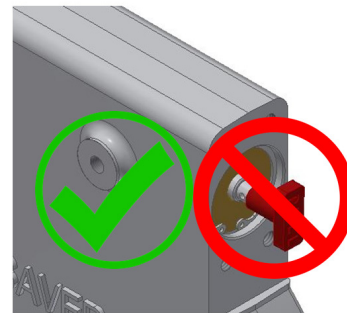

Maintenance Kits

Spindle System Kit

The spindle system is the mechanism that actuates the valve. With extended exposure to temperature and vibration, the components should be replaced periodically. Upgrading this system to the latest design improves the activation reliability.

Also, the new spindle design has a larger release handle and steel helix ramp. This allows for an alternate method to de-latch the valve.

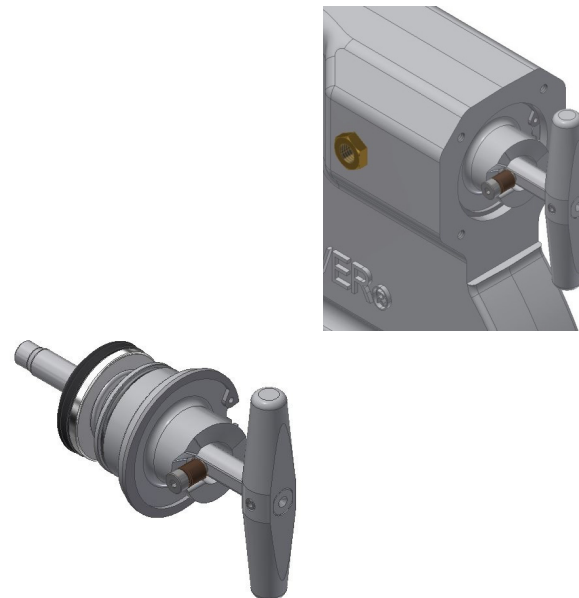

Gate Support Kit

The Gate Support is critical to reducing wear on other valve components.

The gate support mechanism engages the valve gate in the retracted position (open) in order to reduce wear caused by vibration. The life of the gate support mechanism can be greatly affected by the application and should be inspected by the operator.

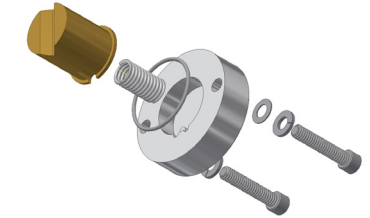

Cover Kit Upgrade

Upgrade your Legacy 11SGE Air Shutoff valve with our Cover Kit. It incorporates all the features and benefits of the Next Generation Valve. Cover Kit includes all components required to upgrade the spindle system and gate support mechanism as detailed below.

Easy field conversion - simply remove the cover from the installed body and replace with preassembled Cover Kit Upgrade.

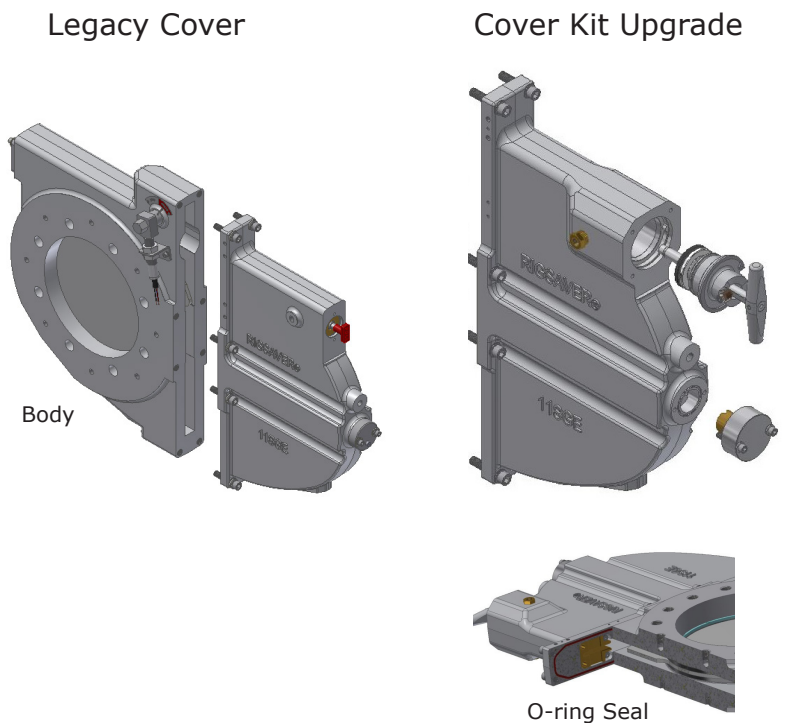

Non-Contact High-Temp Switch Kit

We offer a non-contact, high-temperature proximity switch for the Next Generation Rigsaver 11SGE shutoff valve. This option can be retrofitted in the field.

